

Operating Instructions

Melt Pressure Sensor DA

Contents:

1. Introduction
2. Operating range and field of application
3. Danger areas
4. Waste disposal
5. Transport and storage
6. Cleaning of the sensors
7. Installing / Uninstalling
8. Connecting and commissioning
9. Technical Data
10. Dimensions



1. Introduction

Melt pressure transducers are precise measuring probes which obtain their measuring accuracy and long life span only if they are properly handled. These operating instructions should be studied carefully before installing the sensor, thus ensuring a trouble-free operation. Nevertheless, should you encounter any difficulties, please feel free to contact our service technicians, who will be pleased to be of assistance.

2. Operating range and field of application

Gneuss melt pressure transducers have exclusively been designed for the pressure monitoring of liquid, doughy or pasty materials at high temperatures. These must have a homogeneous constitution. The application area has to be selected in such a manner, that a max. Differential pressure of 2% of the measuring range - based on the diaphragm surface- is not exceeded. Any use beyond the above mentioned application area does not conform to regulations.

3. Danger areas

In the complete application area of the melt pressure transducer, there is a risk of combustion. If the pressure transducer is not installed or uninstalled correctly during the applying of pressure there is a risk of hot media emerging.

4. Waste disposal

Pressure transducers filled with mercury, have to be disposed of as hazardous waste. A free of charge and ecologically-friendly disposal can be carried out by Gneuss Kunststofftechnik GmbH.

5. Transport and storage

Gneuss pressure transducers are generally dispatched in separate packages. In case of mechanical exposure, the sensing diaphragm is protected by an aluminium cap. This cap should be screwed on at all times of storage.

6. Cleaning of the sensors

In order to clean the diaphragm, the sealing surface and the process thread the sensor must have the same temperature as the plastic melting point. The diaphragm and the sealing surface can be wiped down with a soft cloth, the thread can be cleaned with a steel brush. **(Do not come into contact with the diaphragm surface).**

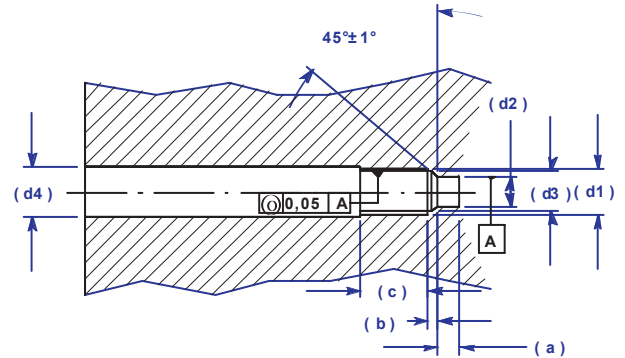

7. Installing / Uninstalling

Installing

On installation of the pressure transducer it is imperative to note, that the sensor bore corresponds to the dimensions mentioned below. The fitting accuracy can be checked by means of a test bolt

Prior to mounting the sensor, the thread should be covered with a heat resistant paste. Should the machinery with the sensor drilling still be at production temperature, a certain preheating period for the sensor should be taken into consideration, in order to avoid a seizing of the sensor due to thermal expansion.

On mounting the transducer, it is important to note that the sensor is not screwed in at an angle and that the sensor does not fall into the bore.

Starting torque for 1/2-20 UNF = max. 30 Nm

Starting torque for M 18 x 1,5 = max. 50 Nm

Uninstalling

The uninstalling of the pressure transducer has to be done in a heated up condition (plastic melting point) On removal of the sensor, please take note that the diaphragm is not brought into contact.

d1	M18x1,5	1/2"20UNF 2A
d2	$\varnothing 10,1^{+0,05}$	$\varnothing 7,9^{+0,05}$
d3	$\varnothing 16,1^{+0,1}$	$\varnothing 10,7^{+0,1}$
d4	$\varnothing 20^{+0,2}$	$\varnothing 13^{+0,2}$
a	$6,1^{-0,1}$	$5,7^{-0,1}$
b	$4^{-0,2}$	$3,2^{-0,2}$
c	25	19

8. Connections and commissioning

After the pressure transducer has been mounted into the line as is described in section 7, the electrical connection then has to be carried out according to the connections indicated on next page. Gneuss pressure transducers are equipped with high-quality and robust plug connections. The connecting wire should be soldered with great care since otherwise, transmission errors of signals can be caused. We recommend you to use Gneuss prefabricated connecting wires which are available from stock.

For the commissioning, the sensor and the corresponding evaluation unit (e.g. Gneuss pressure measurement amplifier) have to be calibrated accordingly. The calibrating process has to be carried out when the line is heated up and at zero pressure. Please take the details concerning the way how to proceed from the respective operating instructions for the evaluation unit.

Electrical wiring

Plug type in sensor **PT 02A-10-6P**

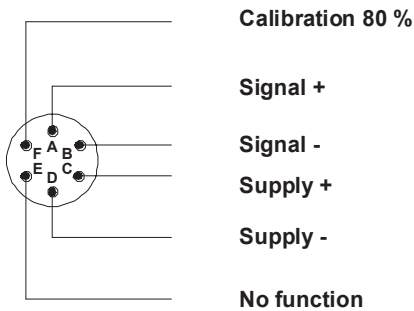

Plug type socked **PT 06W-10-6S**
 Gneuss order number: E0000_0043

Pin	Function	Colour scheme (Gneuss - cables)
A	Signal +	yellow
B	Signal -	white
C	Supply +	brown
D	Supply -	green
E	No function	pink
F	Calibration 80%	grey

9. Technical Data

Pressure range:	See order specification
Supply:	6...10V maximum current consumption 28,6 mA @ 10V
Outputsignal:	2mV/V respectively 3,3 mV/V (see order specification)
Bridge resistance:	350 Ohm
Calibration point:	80 % of measuring range
Accuracy:	$\leq \pm 0,50$ % FSO respectively $\leq \pm 0,25$ % FSO (see order specification)
Maximum over load:	150% of measuring range
Zero deviation with Temperature Variations at the membrane:	$\leq \pm 0,003$ % from final value/°C
Zero deviation with Temperature Variations at the measuring head:	$\leq \pm 0,003$ % from final value/°C
Maximum temperature at The membrane:	400 °C
Maximum. Temperature at The measuring head:	125 °C
EMC:	Electromagnetic disturbances and electromagnetic susceptibility according to EN 61326
Degree of protection:	IP 55

10. Dimensions

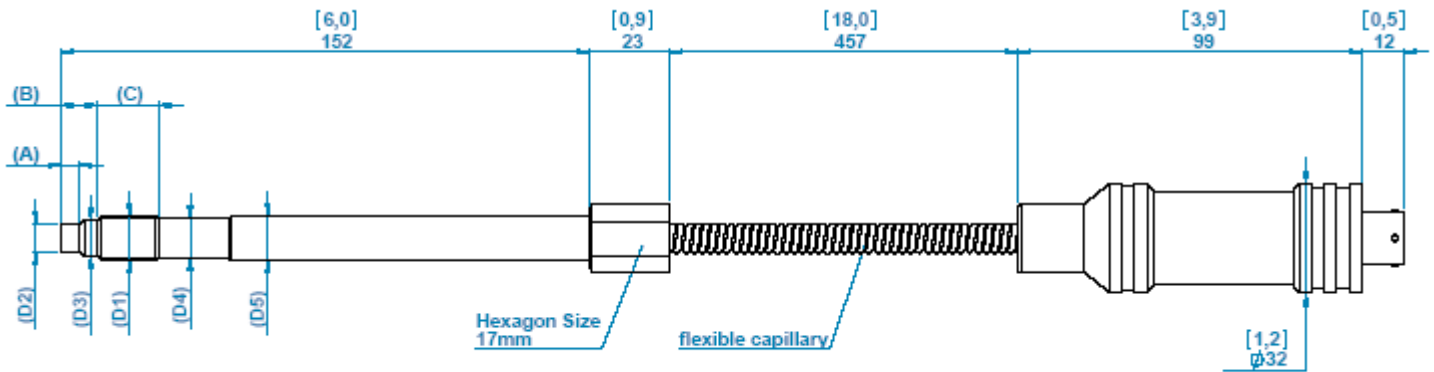
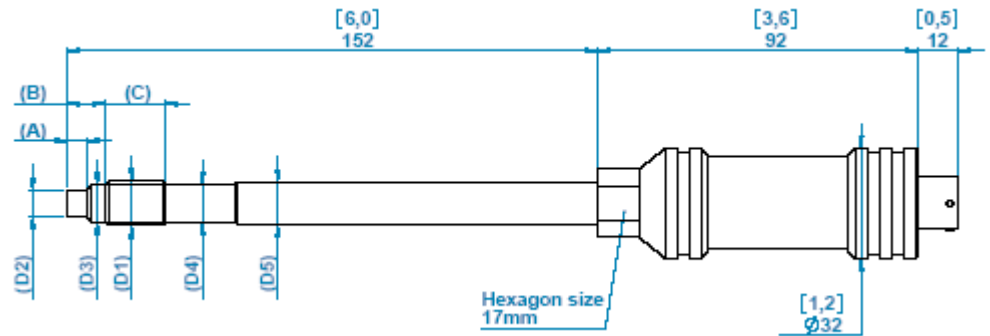

For available variations see order specification

Gneuss Kunststofftechnik GmbH
 Moenichhusen 42
 32549 Bad Oeynhausen
 Germany
 Phone: +49 5731 5307-0
 Fax: +49 5731 5307-77
 Email: gneuss@gneuss.com
 www.gneuss.com

